

Technical data sheet

Product features



Cooking range s induction electric

Model	SAP Code	00014759
--------------	-----------------	----------



- Device type: Electric unit
- Power consumption of the zone 1 [kW]: 3,5
- Protection of controls: IP24
- Material: AISI 304 top plate and cladding

SAP Code	00014759	Power electric [kW]	3.500
Net Width [mm]	400	Loading	400 V / 3N - 50 Hz
Net Depth [mm]	730	Number of zones	1
Net Height [mm]	300	Power consumption of the zone 1 [kW]	3,5
Net Weight [kg]	43.00		

Technical data sheet

Technical drawing



Cooking range s induction electric

Model	SAP Code	00014759
--------------	-----------------	----------

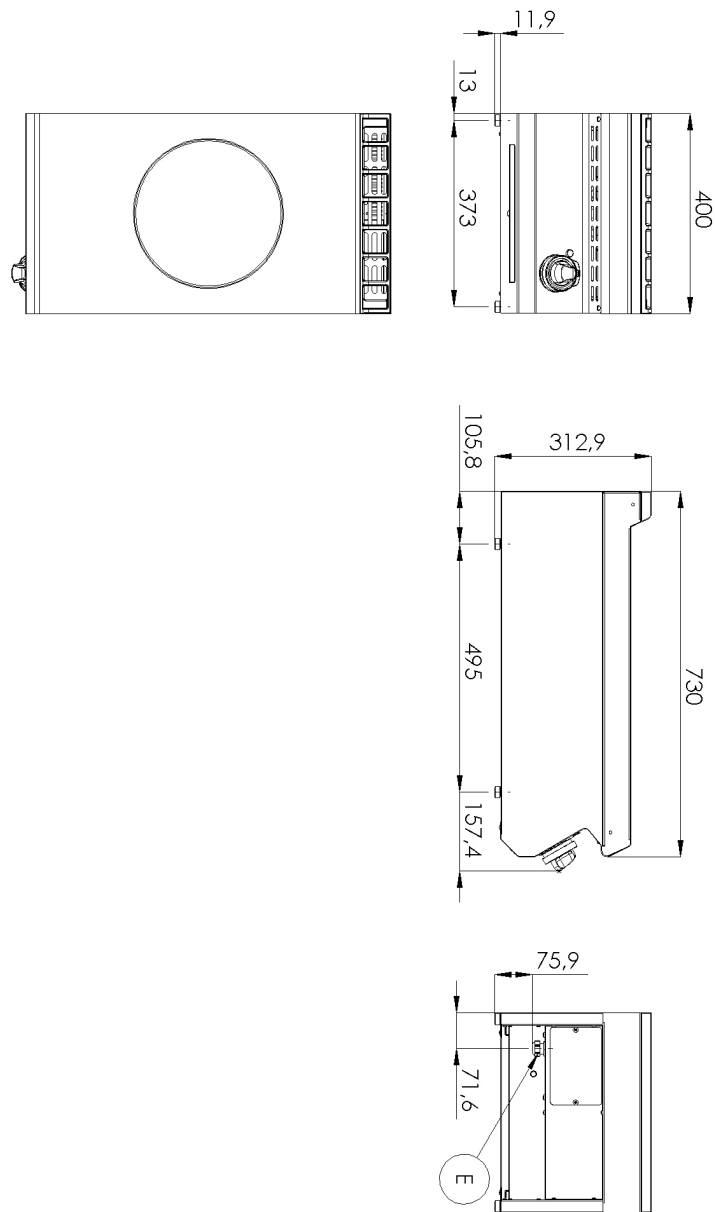

Technical data sheet

Technical parameters



Cooking range s induction electric

Model

SAP Code

00014759

1. SAP Code:

00014759

2. Net Width [mm]:

400

3. Net Depth [mm]:

730

4. Net Height [mm]:

300

5. Net Weight [kg]:

43.00

6. Gross Width [mm]:

460

7. Gross depth [mm]:

820

8. Gross Height [mm]:

480

9. Gross Weight [kg]:

50.00

10. Device type:

Electric unit

11. Construction type of device:

Table top

12. Power electric [kW]:

3.500

13. Loading:

400 V / 3N - 50 Hz

14. Protection of controls:

IP24

15. Exterior color of the device:

Stainless steel

16. Material:

AISI 304 top plate and cladding

17. Indicators:

operation

18. Worktop type:

Molded - comfortable cleaning maintenance

19. Worktop material:

AISI 304

20. Worktop Thickness [mm]:

1.50

21. Number of zones:

1

22. Power consumption of the zone 1 [kW]:

3,5

23. Service accessibility:

Trough the frontal panel

24. Number of burners/hot plates:

1

25. Type of electric cooking zones:

Induction

26. Cross-section of conductors CU [mm²]:

1

- Výkon (kW): 3,7-5 (230 V); 6,4-8,7 (400 V)